

Dressler ARA-2000 active antenna – what’s inside ?

Matthias Bopp
Updated June 22nd 2014

Dressler active antennas have an excellent reputation and thus I was interested how they are comprised before buying one. The ARA-2000 antenna was my first choice as this wideband antenna (50 – 2000 MHz) could be a nice fit to my wideband receiver AOR AR-8600. The ARA-2000 is a very compact wideband antenna in a plastic tube with a diameter of 9 cm and a length of 45cm. Its weight is only 2 kg. The set includes a Bias-T which is placed close to the receiver and feeds the supply voltage/current via the coaxial cable to the active antenna. The original Bias-T was in a grey plastic box, the newer is the RSM-2000 (40kHz-2150 MHz) shown in the picture below. Here is a picture of the antenna (left) and the newer Bias-T (right):



When looking for data of this antenna I found out that there were multiple versions available. Here are the electrical specifications for the original ARA-2000 (shown above):

Noise figure:	2.0-3.5 dB (50-1000 MHz)
	3.5-4.0 dB (1000-2000 MHz)
Gain:	18-22 dB (50-1500 MHz)
	14-17 dB (1500-2000 MHz)
Output impedance:	50-75 Ohms
Supply voltage:	11.5-14 VDC Supply current: typ. 120 mA

Later Dressler introduced versions ARA-2000LL (low loss) and ARA-2000HDX (for high RF environments). Below description may not apply to the later versions.

So, let’s see what’s inside the white tube ?

I got hold of some pictures of the electronics but initially not of the antenna structure. Please note that there are at least 3 different versions of the electronics existing. The antenna structure is described as a modified conical antenna structure, which allows for very wideband

reception and can pick up signals in both the vertical and horizontal fields, although vertical polarization is preferred. Here is a sketch of the antenna on how I interpreted some of the verbal descriptions of the wideband dipole with round copper clad discs for capacitive loading on the top and bottom. It is yet unclear to me on how the dipole is fed and balanced. Possibly the lower dipole has a printed structure on the back side acting as feed-line as well as a balun.

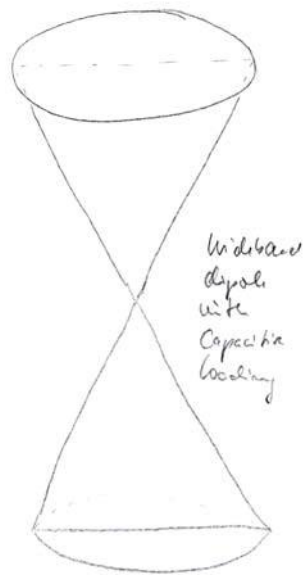

In October 2011 another radio amateur had to open an ARA-2000 in order to repair the defective electronics. Walter DO7WW was kind enough to provide me some pictures of the one he successfully fixed.

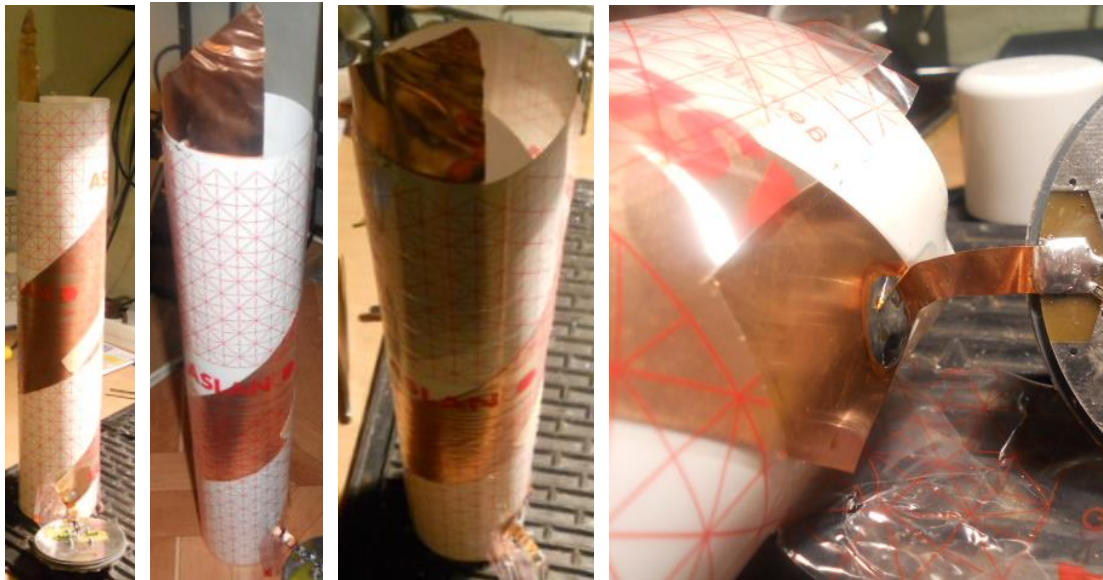

As can be shown the antenna element is a copper foil attached to a paper cylinder and sealed with some transparent plastic foil. The monopole has the shape of a rhombus which is narrow at both ends wider in the center. This monopole is wound around the paper cylinder. This is very different to the suggested balanced dipole structure described before.

The electronic part of the active antenna is a round PCB which is glued in the bottom of the tube and includes the N type connector for the coaxial cable running to the receiver as well as the amplifier circuit. Apparently there are at least 2 versions of the PCB available.

Here is the first version of the electronics I am aware of. The pictures were provided by Walter DO7WW. It consists of 2 MMICs amplifiers which are cascaded. The type of the MMICs are not 100% know to me but most likely they are Avantek (today Avago) MSA-1105 Si-MMICs. The specification, package type and marking (Top A, bottom H) support this assumption.

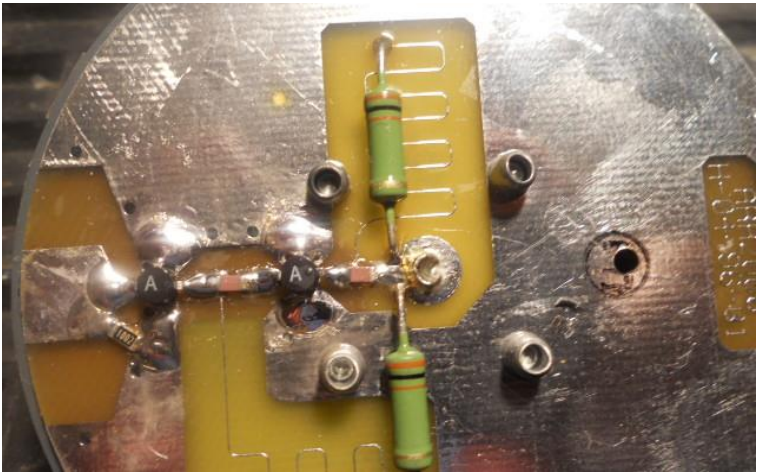
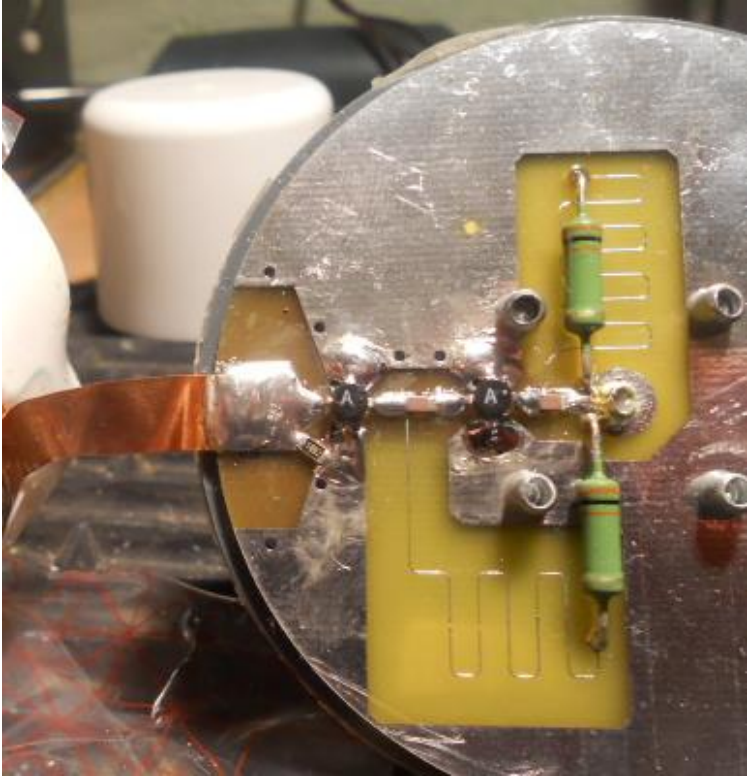

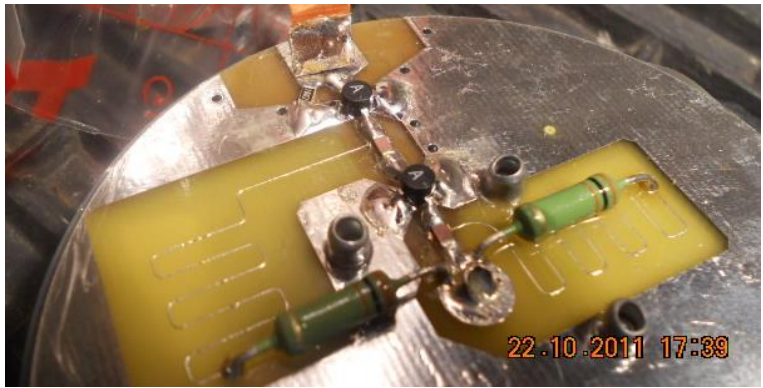

The MSA-1105 MMIC is a high dynamic range 50 Ohm or 75 Ohm gain block with a 3dB bandwidth of 50 MHz to 1.3 GHz. The 1dB compression point at 500 MHz is P1dB=17.5 dBm. The typical noise figure at 500 MHz is 3.6 dB. The package is a “05” surface mount

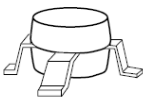

plastic package:

The circuit in the ARA-2000 is identical to the typical application circuit as proposed by Avantek.

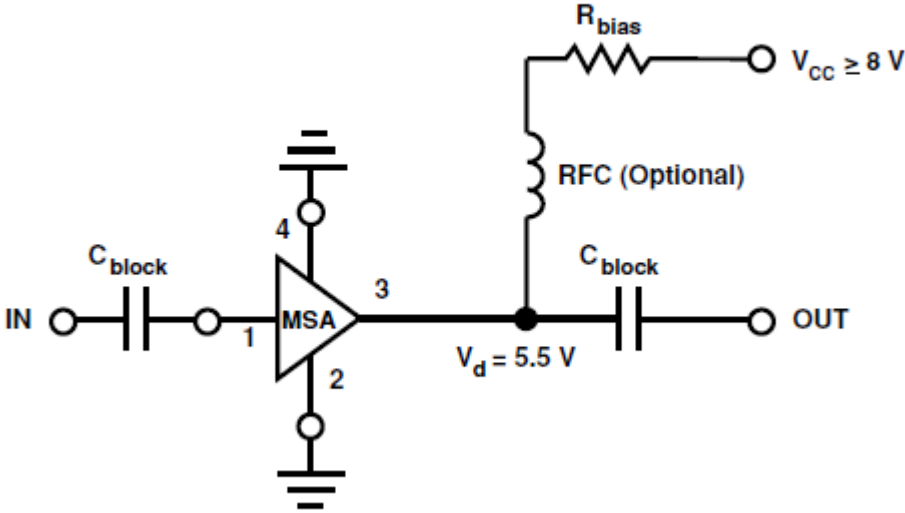

Here are the key data of this MMIC:

Electrical Specifications^[1], $T_A = 25^\circ\text{C}$

Symbol	Parameters and Test Conditions: $I_d = 60\text{ mA}$, $Z_o = 50\ \Omega$	Units	Min.	Typ.	Max.	
G_P	Power Gain ($ S_{21} ^2$)	$f = 0.05\text{ GHz}$	dB		12.7	
		$f = 0.5\text{ GHz}$	dB	10.0	12.0	
		$f = 1.0\text{ GHz}$	dB		10.5	
ΔG_P	Gain Flatness	$f = 0.1\text{ to }1.0\text{ GHz}$	dB		± 1.0	
$f_3\text{ dB}$	3 dB Bandwidth ^[2]		GHz		1.3	
VSWR	Input VSWR	$f = 0.1\text{ to }1.0\text{ GHz}$			1.5:1	
	Output VSWR	$f = 0.1\text{ to }1.0\text{ GHz}$			1.7:1	
NF	50 Ω Noise Figure	$f = 0.5\text{ GHz}$	dB		3.6	
$P_{1\text{ dB}}$	Output Power at 1 dB Gain Compression	$f = 0.5\text{ GHz}$	dBm		17.5	
IP_3	Third Order Intercept Point	$f = 0.5\text{ GHz}$	dBm		30.0	
t_D	Group Delay	$f = 0.5\text{ GHz}$	psec		200	
V_d	Device Voltage		V	4.4	5.5	6.6
dV/dT	Device Voltage Temperature Coefficient		mV/ $^\circ\text{C}$		-8.0	

Notes:

1. The recommended operating current range for this device is 40 to 70 mA. Typical performance as a function of current is on the following page.
2. Referenced from 50 MHz gain (G_P).

Here are pictures of the second version with respect to the electronics

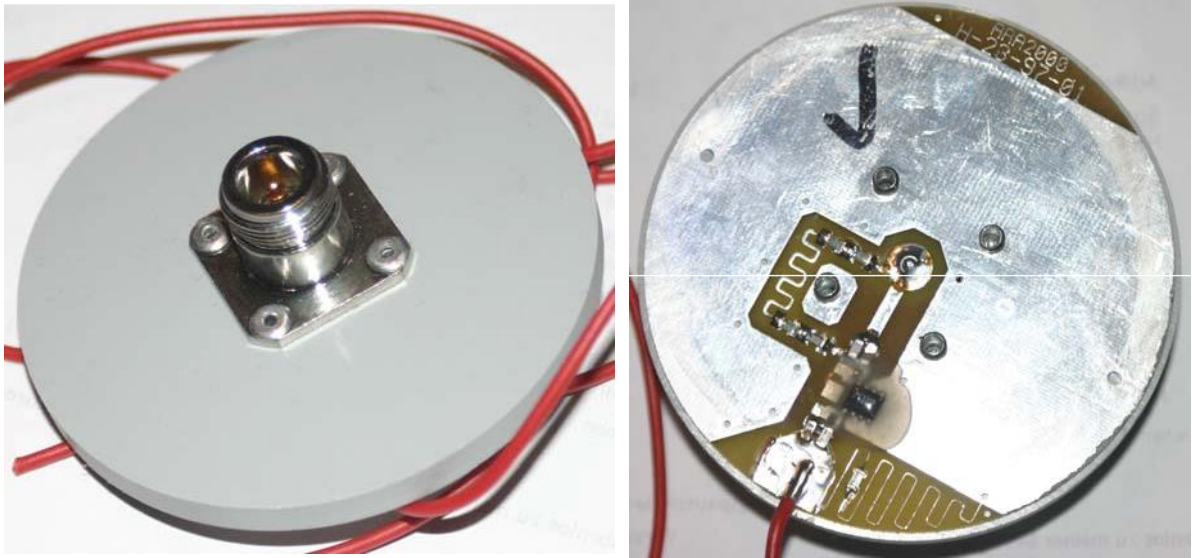

The active section is based on a MMIC (Monolithic Microwave Integrated Circuit) wideband amplifier from RFMD in a SOIC-8 package. The RF2312 is a wideband amplifier originally targeting the TV market. It includes a preamplifier with a low noise figure followed by a high current final stage for maximum strong signal handling performance. Input and output impedances are optimized to 75 Ohms.

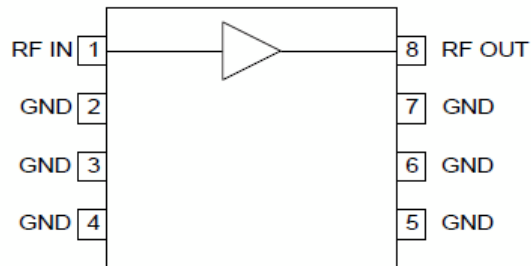

Here are some of the specifications of this MMIC RF2312:

Frequency Range: 0-2500 MHz
Gain typ. 16 dB @ 900 MHz
Noise Figure typ. 3.8 dB @ 50-300 MHz
typ. 4.2 dB @ 300-1000 MHz
OIP3 typ. 38 dBm @ 100 MHz
typ. 36 dBm @ 500 MHz
typ. 30 dBm @ 900 MHz

As you can see, the specs of the complete active antenna are more better than those of the MMIC itself are. Maybe Dressler selected special ICs with higher specifications ?

I doubt it.

Here is a basic application circuit as proposed by RFMD:

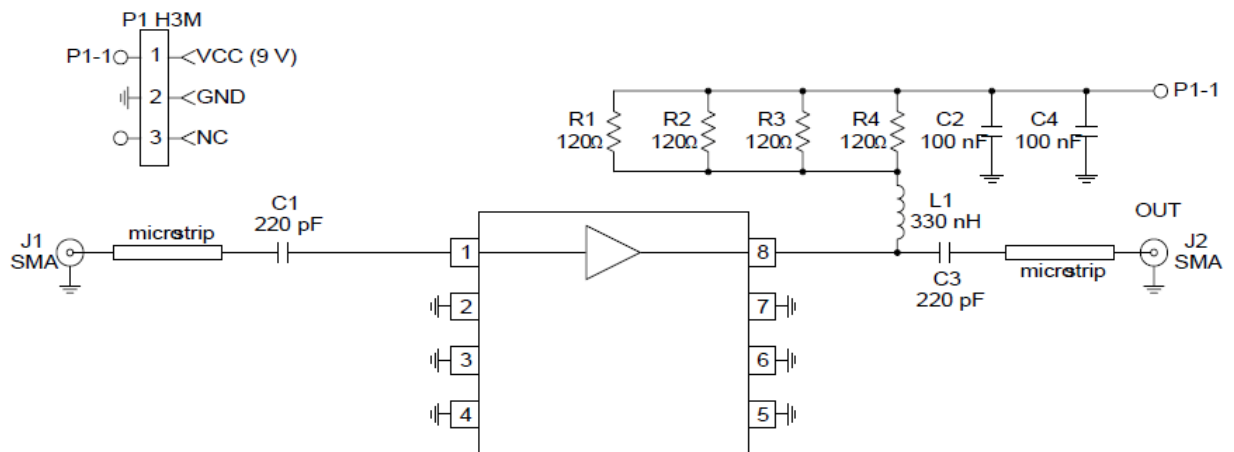

The actual circuit on the PCB (see picture below) is very similar to the test circuit above. The bias input P1-1 is connected to the N-jack for remote bias operation (phantom feed). The input of the MMIC is protected against overloading by strong low frequency signals by a simple high pass filter (lower left structure in the picture below).

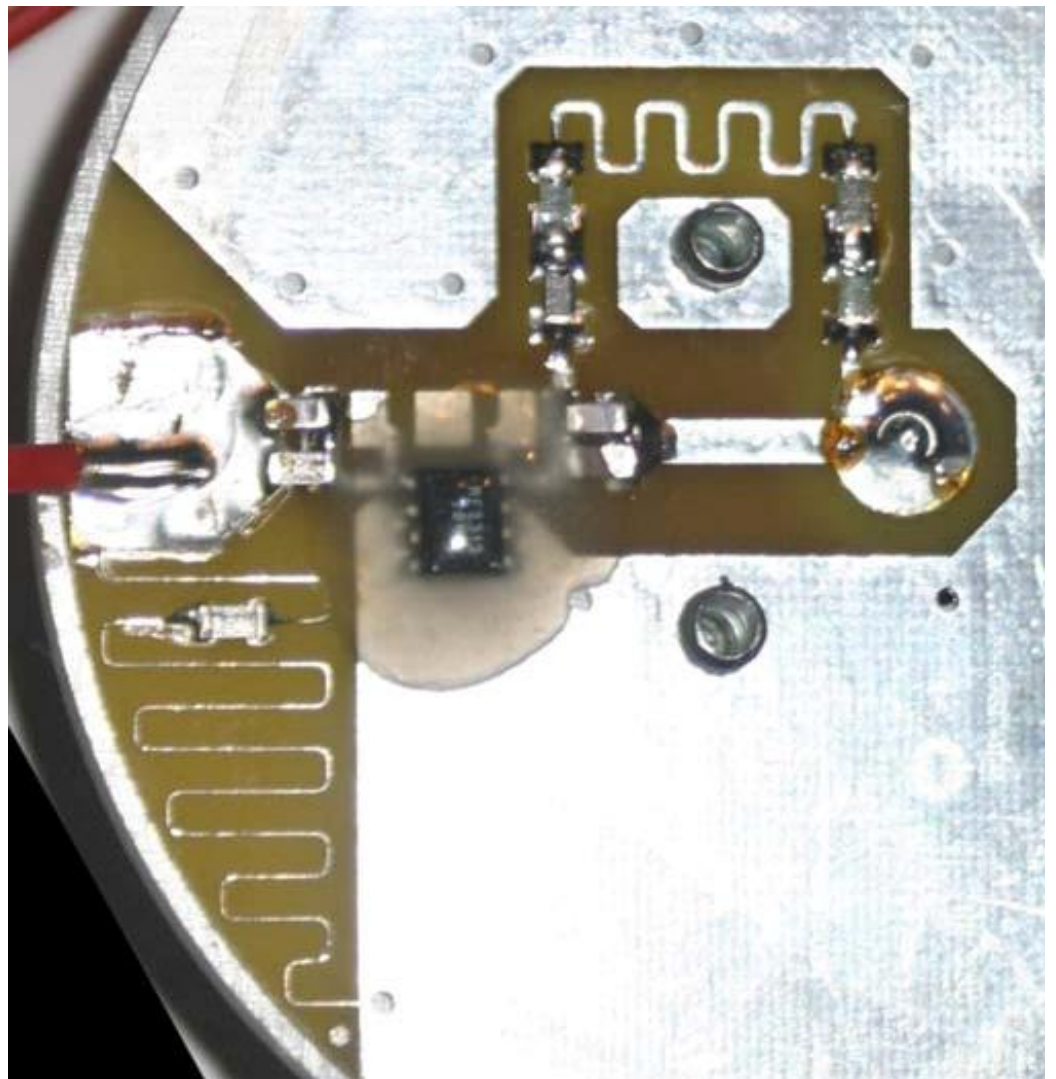

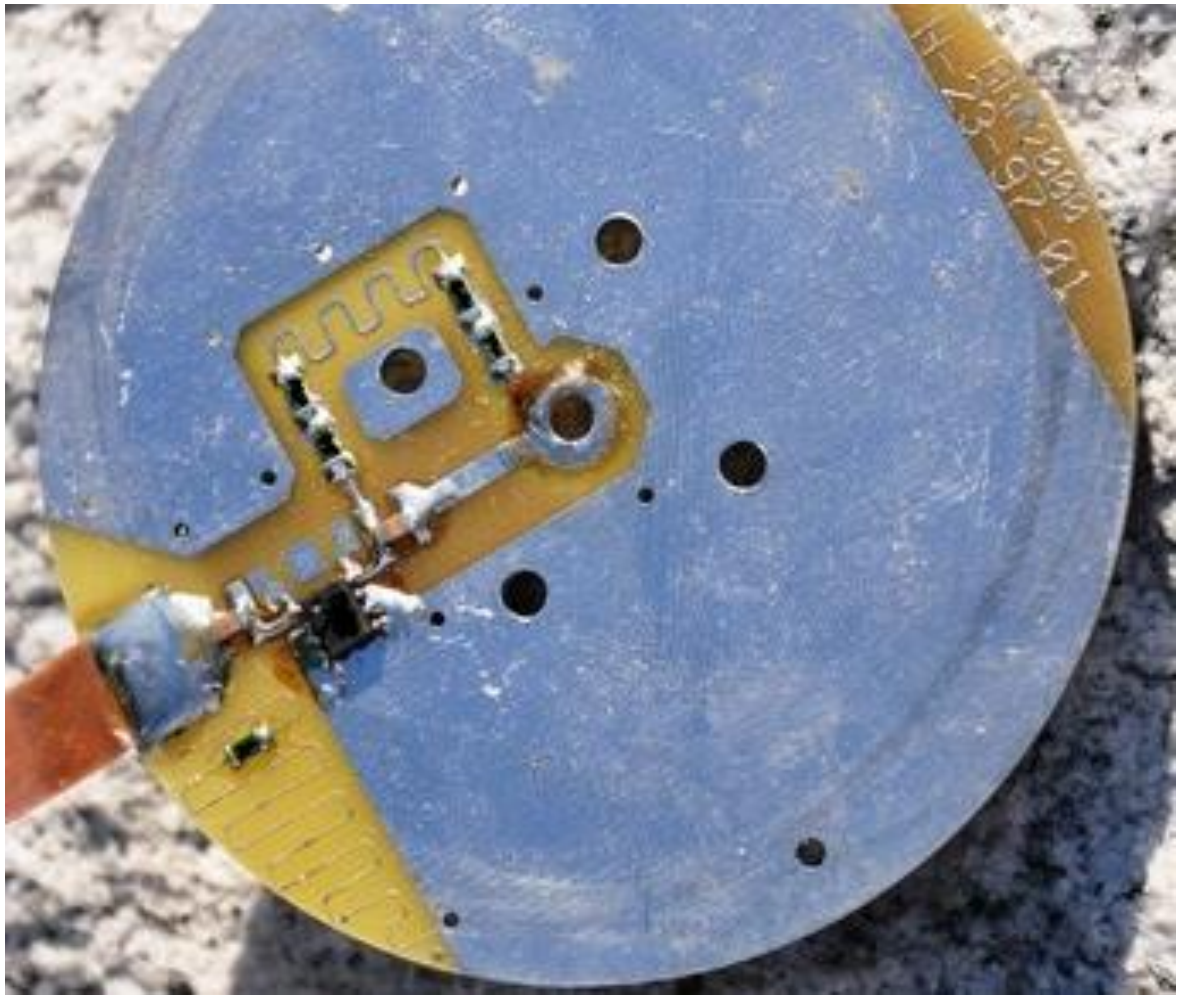

Here are pictures of the third version with respect to the electronics.

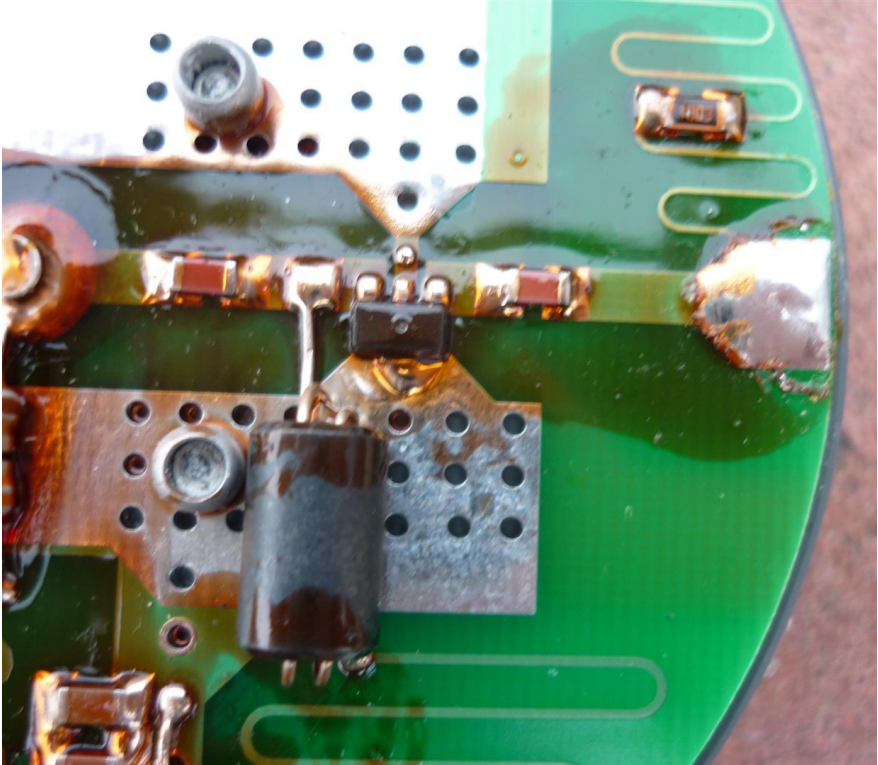
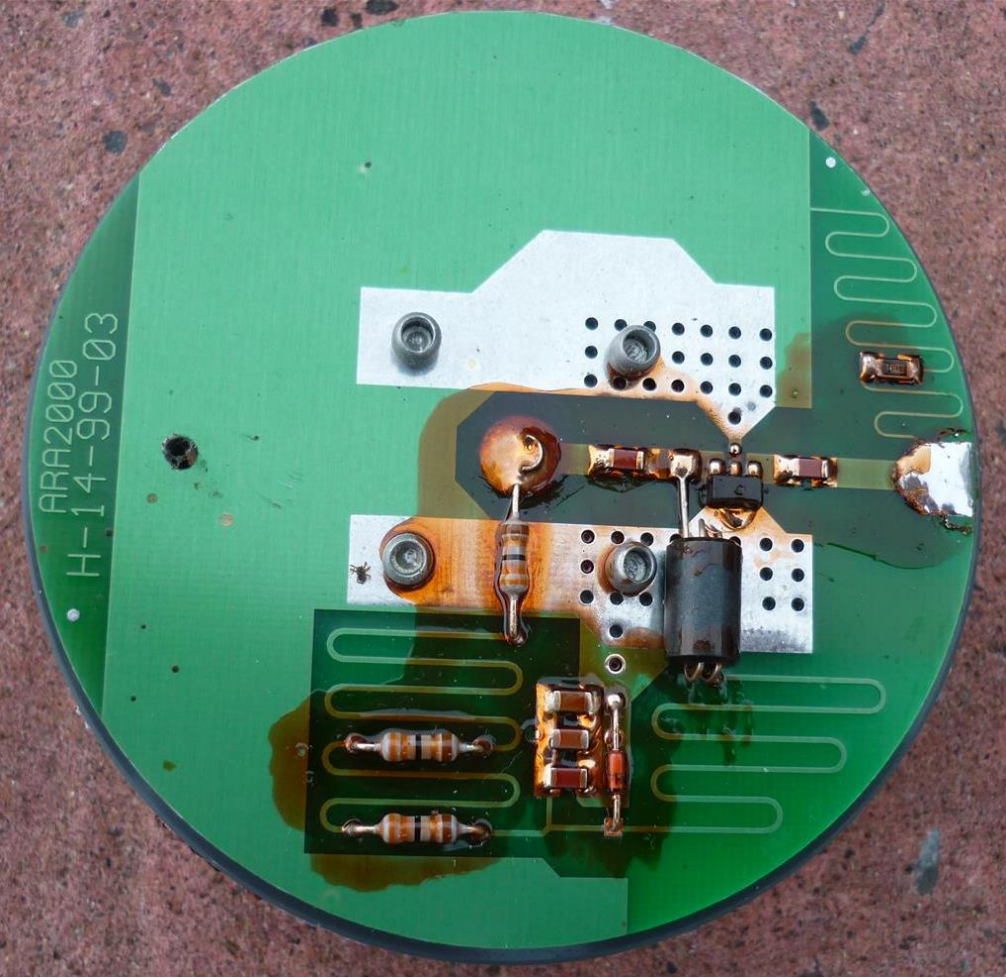

As can be seen this version uses yet another type of MMIC. The application circuit is similar but a protection circuit in case of a reverse biasing has been added. I assume the 3 biasing resistors having each a resistance of 33 Ohms, thus in total 99 Ohms. If the diode is a zener diode then it will provide a basic voltage regulation and protection for the MMIC. I have presently no more data about this version but it is most likely the most recent version.

As a summary I have to state that I am surprised about the very simple construction of this antenna. Based on the first two versions I would expect a quite limited large signal handling capability. As I don't know enough about the third version I cannot judge.

So why has this antenna such a positive reputation?

Maybe this is simply the case because it is very easy to mount and operate. In any case the ARA-2000 offers a very important advantage over any passive antenna systems: the low noise amplifier in the antenna increases the signal before cable losses are degrading the signal to noise ratio. Depending on the cable length used, the additional improvement in reception can be significant.

The production of this antenna has been discontinued and this little description is intended to provide some background information for those who consider buying one second hand, who need to repair their antenna or are interested to build one themselves.

I am always happy to answer questions. Please direct them to my Email address given below.

Best regards

Matthias

Email: ddlus@amsat.org

Homepage: www.ddlus.de