

DC overvoltage protection with BTS555

Matthias, DD1US, rev 1.1, April 26th 2023

Yesterday I experienced a malfunction in the outdoor-unit (ODU) of my QO-100 station. I remotely monitored that the 12V output voltage from the central linear DC power supply was missing. When checking the power supply in the ODU I noticed that indeed the output voltage was missing. After removing the power supply and checking it on my workbench it turned out that the power supply was defective. At the output of the voltage regulator, I measured a voltage of 18V instead of the target 12-13V. Fortunately I had built in an overvoltage protection circuit into the power supply which worked well and disconnected the voltage regulator output from the output terminals of the unit. Thus, it nicely protected the various equipment supplied by this central DC power supply.

While waiting for some parts for repair of the power supply I replaced it with a spare 12V switched mode power supply. As the overvoltage protection had protected my equipment from consecutive damage, I decided to build up another overvoltage protection unit and add it to the switched mode power supply in case this unit may also fail in the future.

The overvoltage protection circuit is based on an Infineon© BTS555, a smart high side high current power switch IC also called PROFET®.

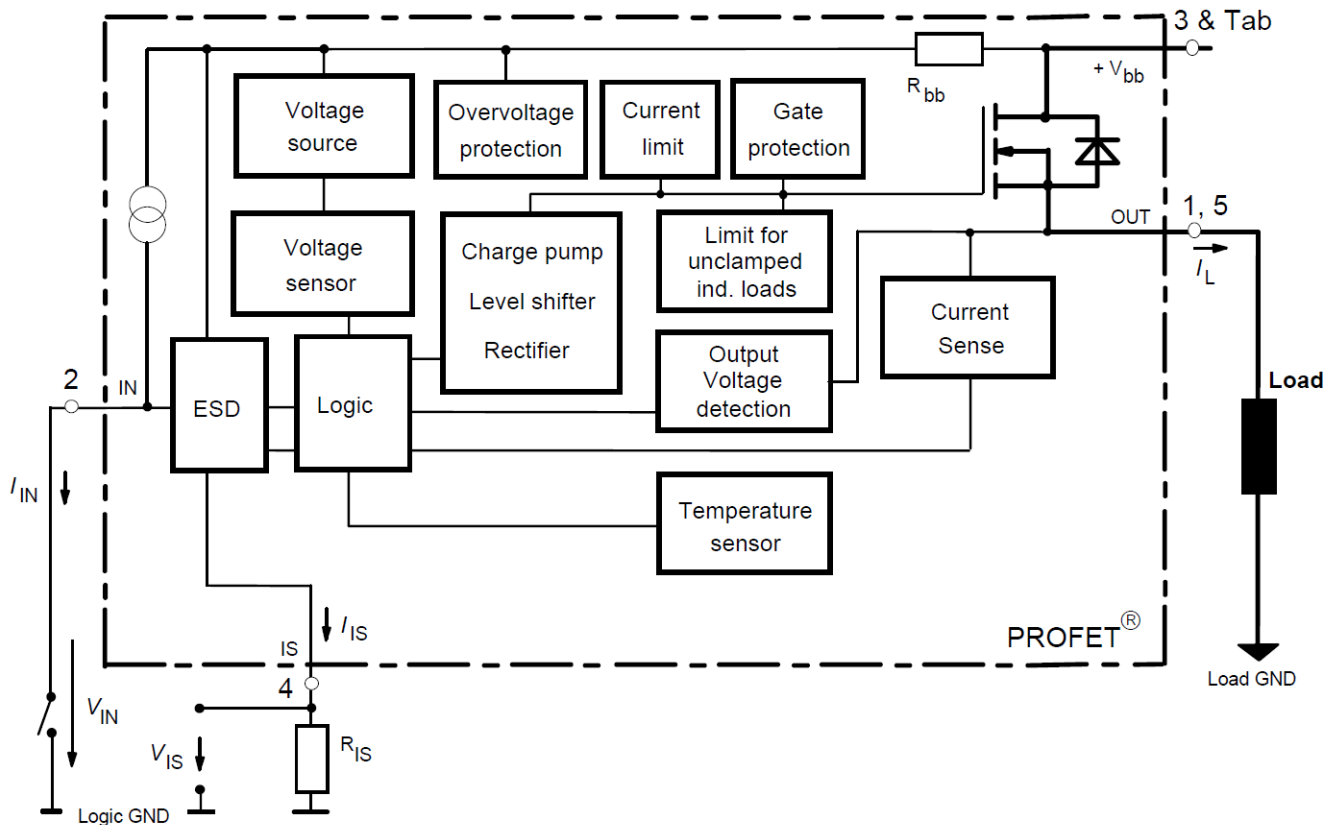

The application circuit was published 2017 by DL1DMW in the German journal "Funkamateu".

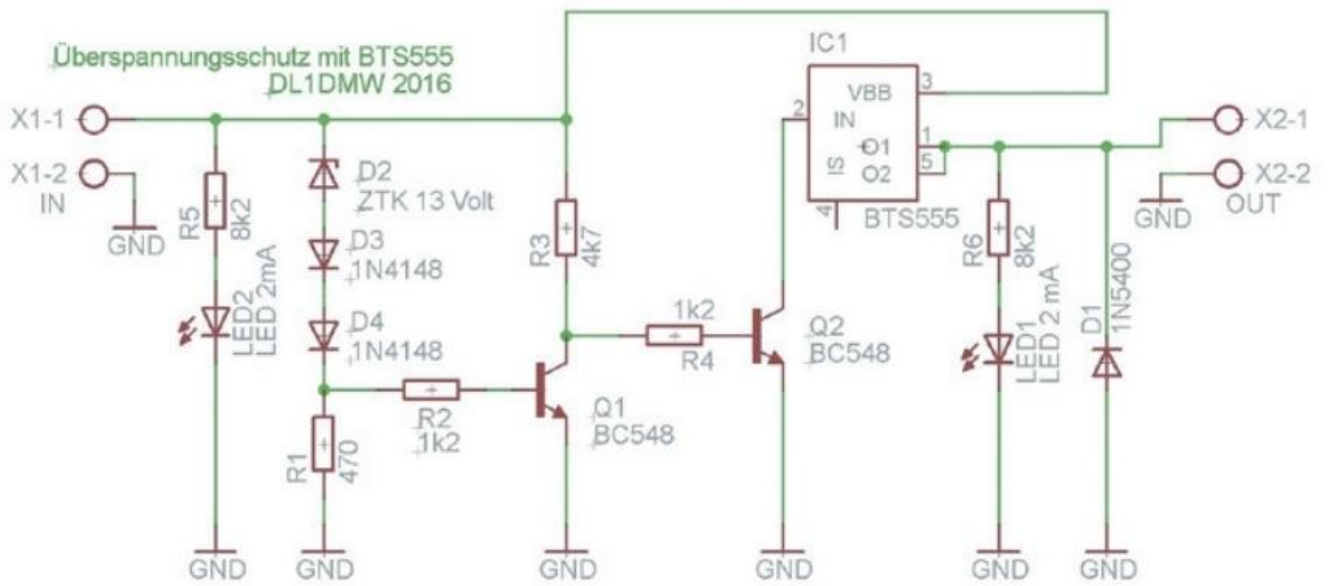

Some time ago a friend of mine, Marek SP4ELF, had kindly designed a PCB for me using mostly SMD components instead of the original board from DL1DMW. Here is the layout of the board:

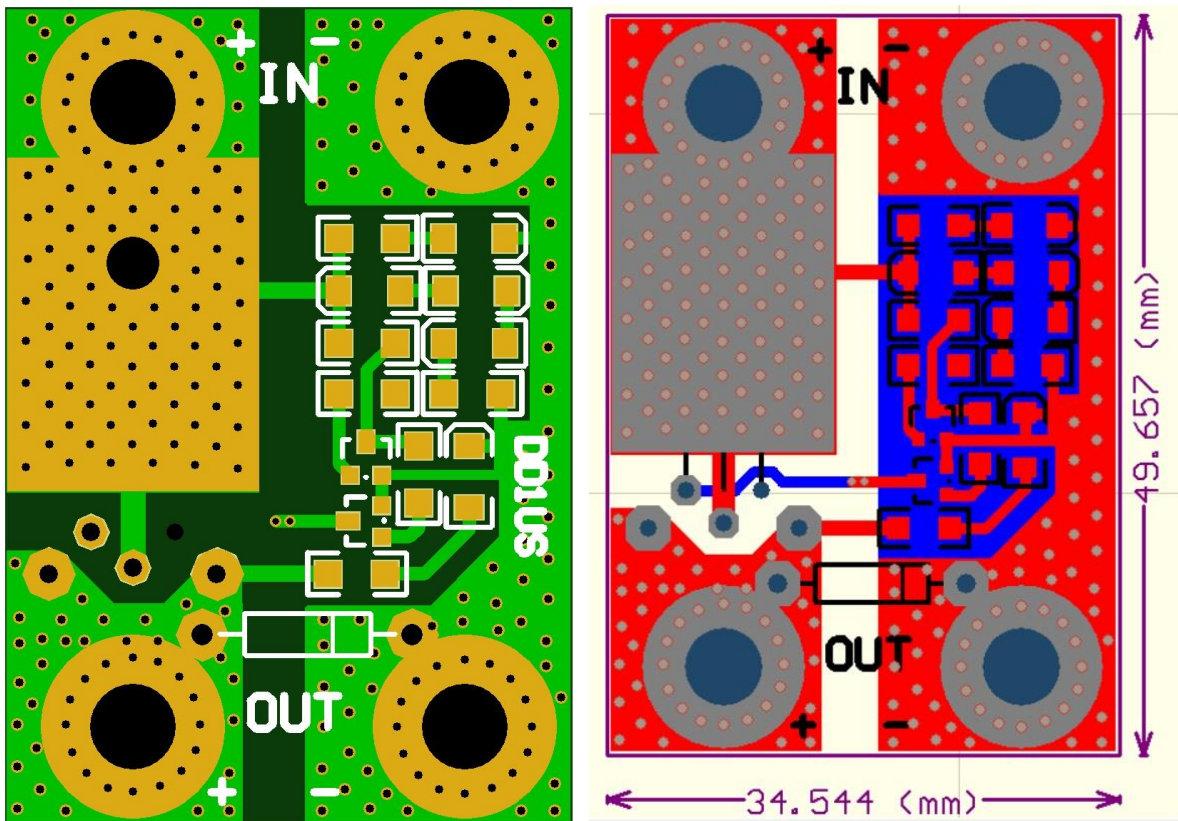

With the selection of the Zener diode voltage and one or two series diodes you can select the voltage, at which the unit will trigger the over voltage protection. In my case I am using a 12V Zener diode plus two series diodes resulting in a trigger voltage of 14.3V.

Here are some pictures of the board, fist partly assembled, then integrated into an encasing.

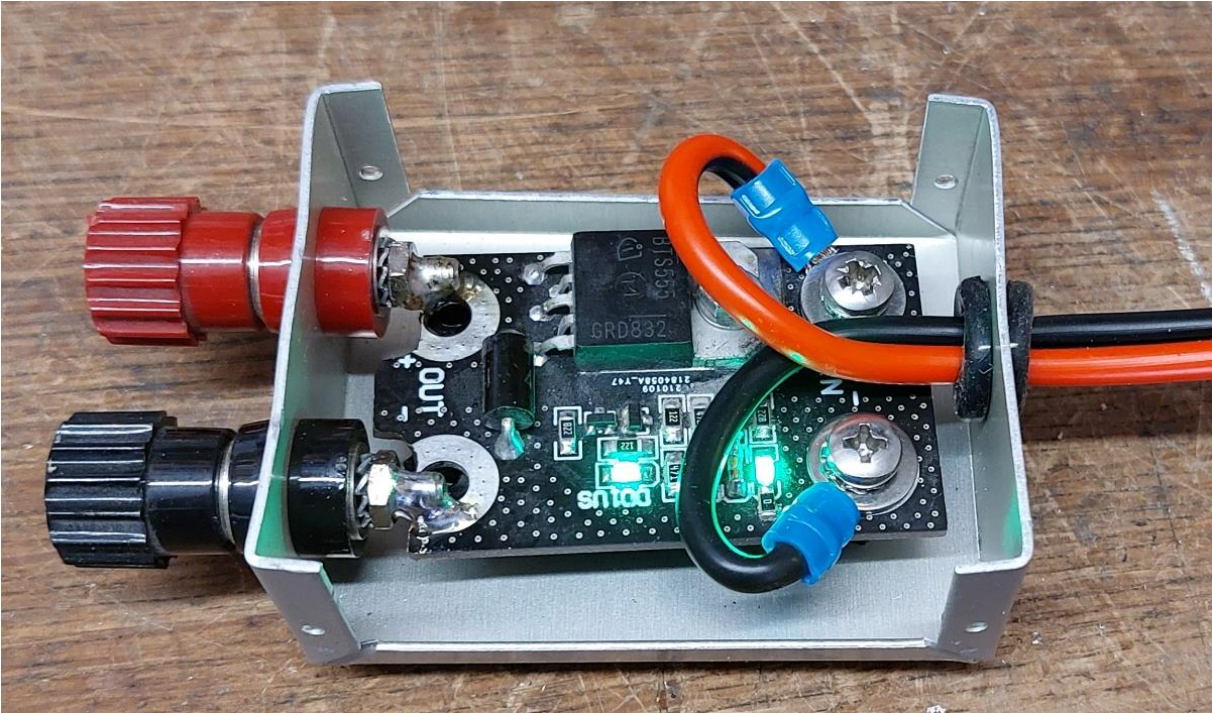
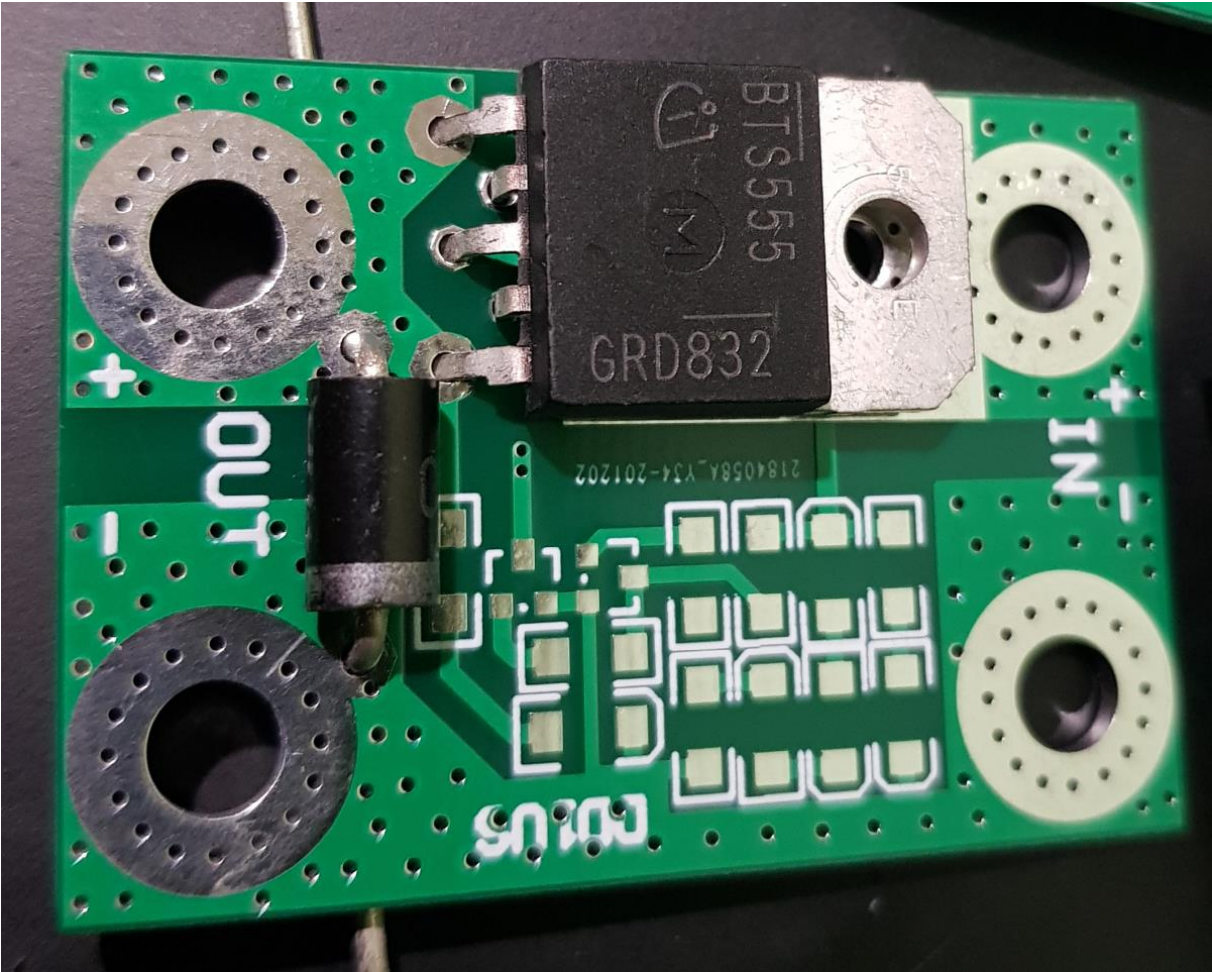

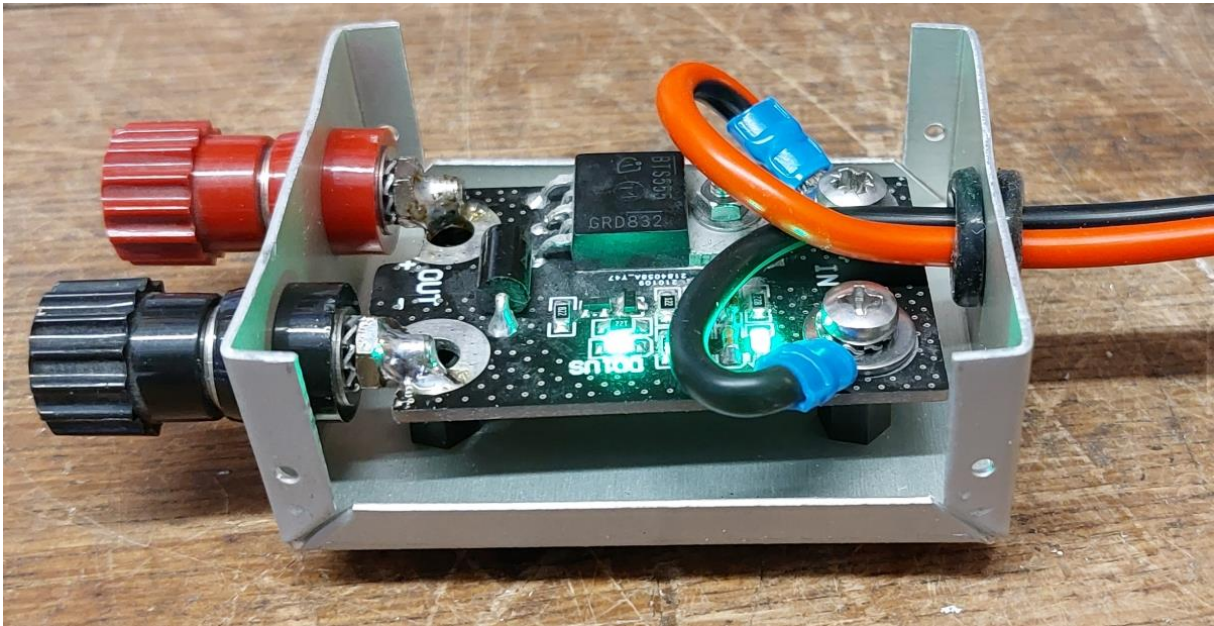

There are 2 LEDs on the board indicating the input and output voltages being present. In order to have them still visible after adding the lid on the encasing I integrated 2 acrylic rods routing the optical signals from the SMD LEDs on the PCB to the top of the lid. In the following pictures you see on the left both LEDs active as the unit is working nominally and on the right side only the input LED active as the output is shut off due to an overvoltage condition.



Here is the layout of the updated board:

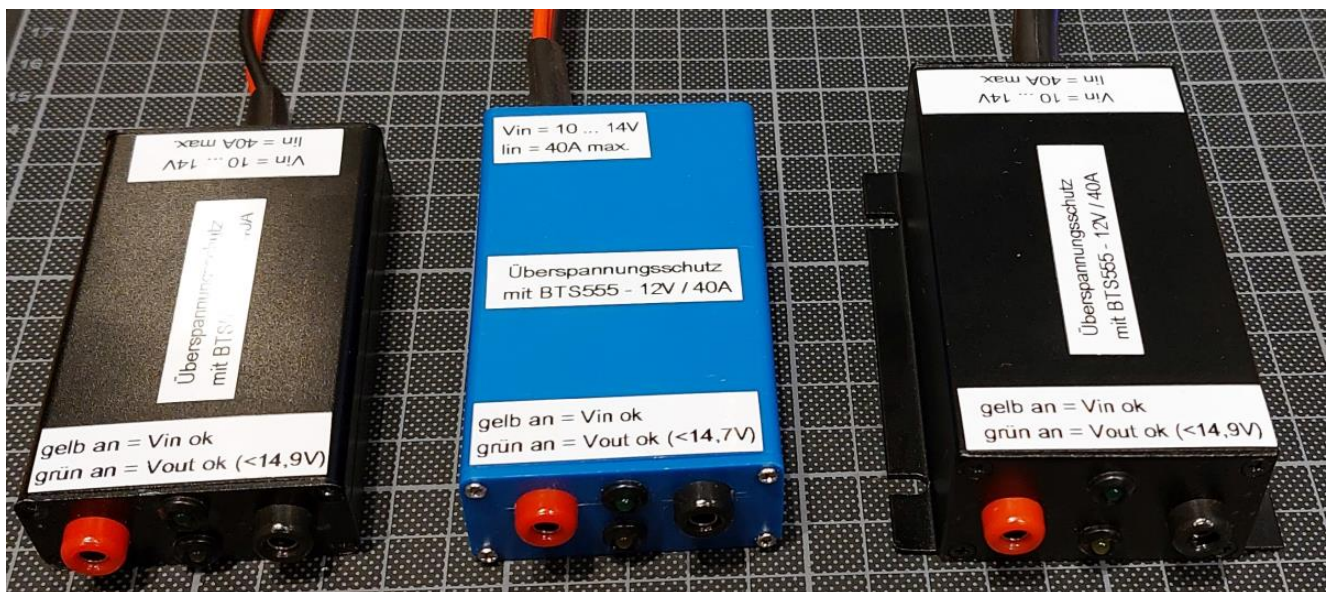
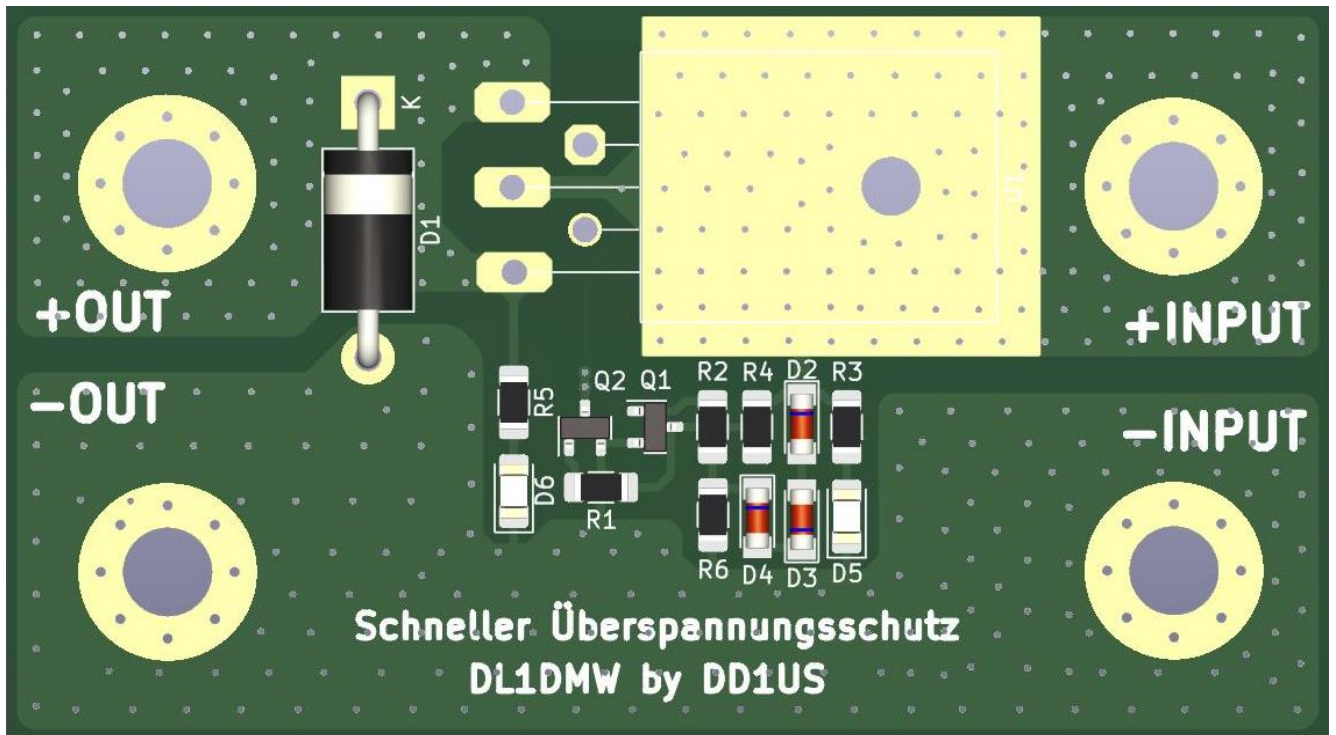

I can highly recommend to add an overvoltage protection to your main power supply in the shack. Often several expensive transceivers or other equipment are connected to one power supply which will result in significant damage in case the power supply fails

Unfortunately, the BTS555 is no more in production but parts can still be found on the surplus market.

Comments and questions are always welcome. Please send them to the Email address given below.

Best regards

Matthias DD1US

Email: DD1US@AMSAT.ORG

Homepage: <http://www.dd1us.de>